

230

Spade type drill made of solid carbide.

Application/Advantages:

- **drilling of high-quality multi-layer boards**
- **the optimised undercut geometry gives an excellent hole quality by less drill deflection**

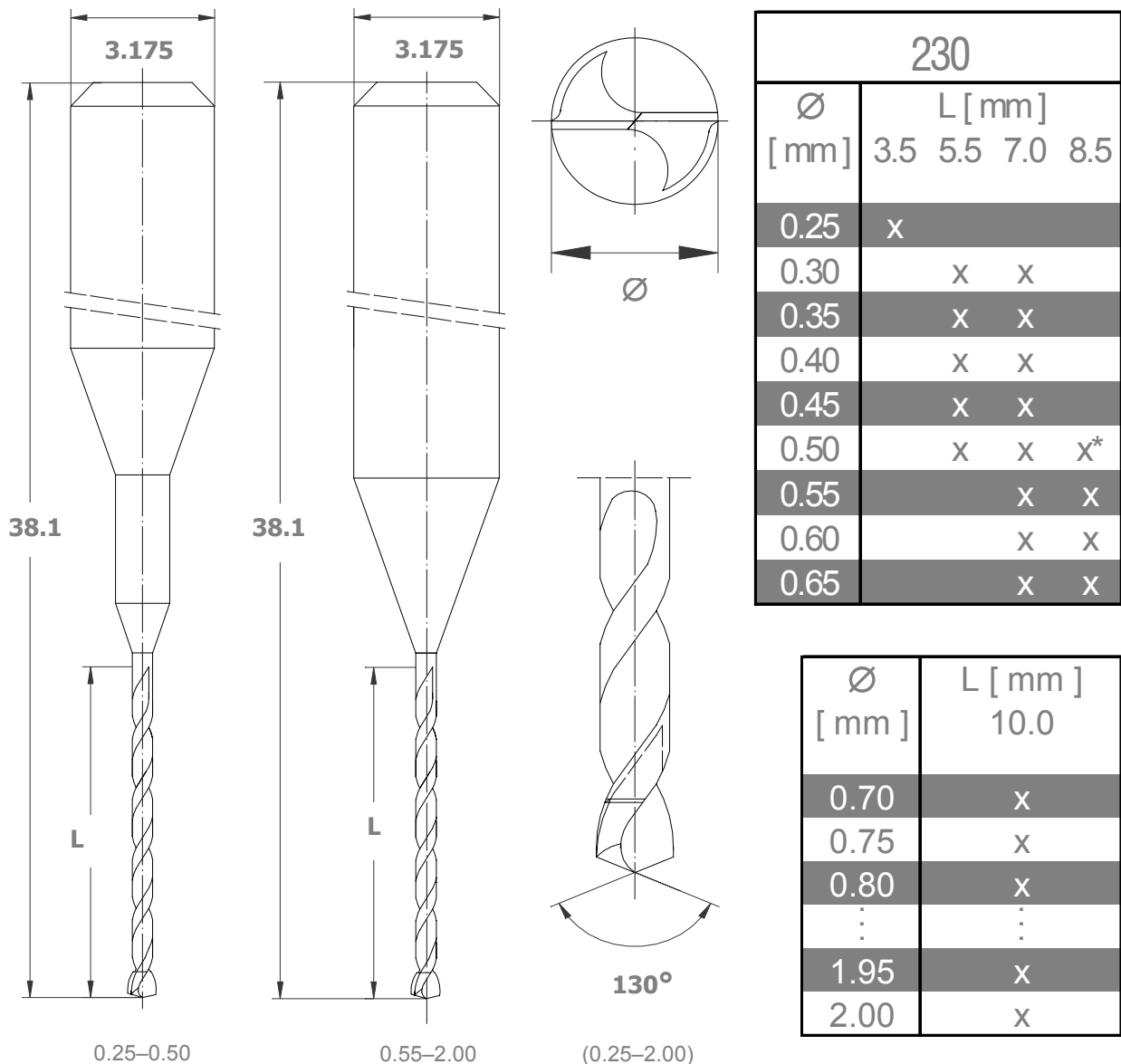

* on request